



# INSTALLATION INSTRUCTIONS

Accessory

**FAIRING POUCH  
P/N 08L56-MCA-100A**

Application

**GL1800**

Publications No.

**MII 11185**

Issue Date

**July 2005**

**Honda Dealer: Please give a copy of these instructions to your customer.**

## PARTS LIST

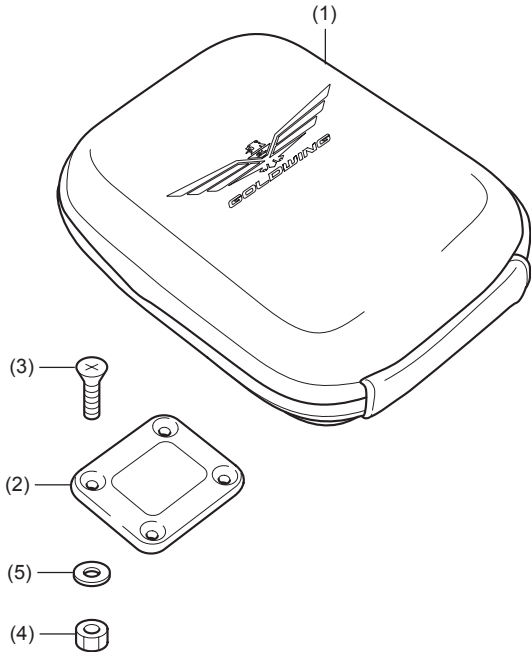

No.	Description	Qty
(1)	Fairing pouch	1
(2)	Fairing pouch base	1
(3)	4 mm screw	4
(4)	4 mm nut	4
(5)	Washer	4

## TOOLS AND SUPPLIES REQUIRED

Electric drill motor  
 Drill bit, 4.5 mm (#16)  
 Phillips® screwdriver  
 Electric tape  
 Marker  
 Ruler  
 Isopropyl alcohol  
 Shop towel

## TORQUE CHART

Tighten all screws, bolts and nuts to their specified torques. Refer to the Service Manual for the tightening torques of removed parts.

Item	N·m	kgf·m	lbf·ft
4 mm screw	1	0.1	0.7

## INSTALLATION

1. Position the fairing pouch base on the left front pocket to the dimension shown. Mark the front pocket through the fairing pouch base.

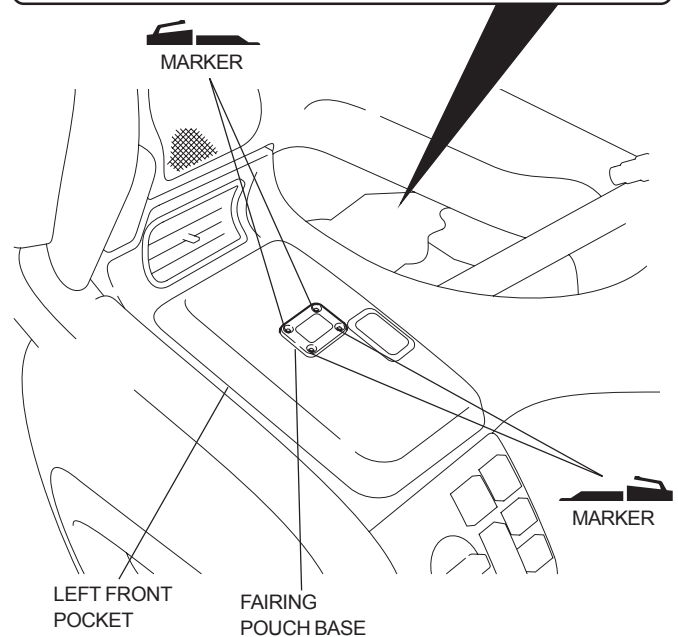
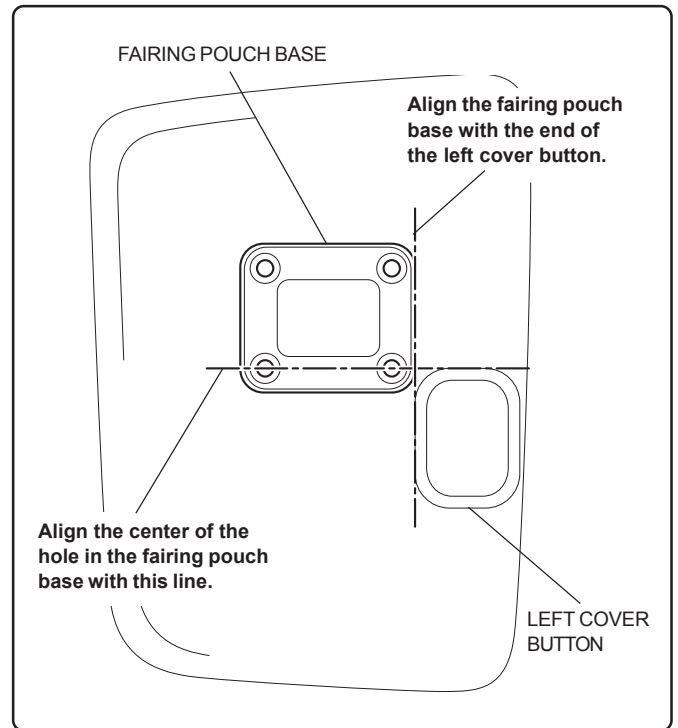

2. Remove the fairing pouch base and drill at the marked points on the front pocket using an electric drill motor.
  - Remove any burrs from the edge of the hole.

Wind the tape around the drill bit to serve as a depth gauge. Leave 10 mm (0.394 in) of the drill bit exposed. Stop drilling when the tape meets the surface of the pocket.

ELECTRICAL TAPE  
10 mm (0.394 in)

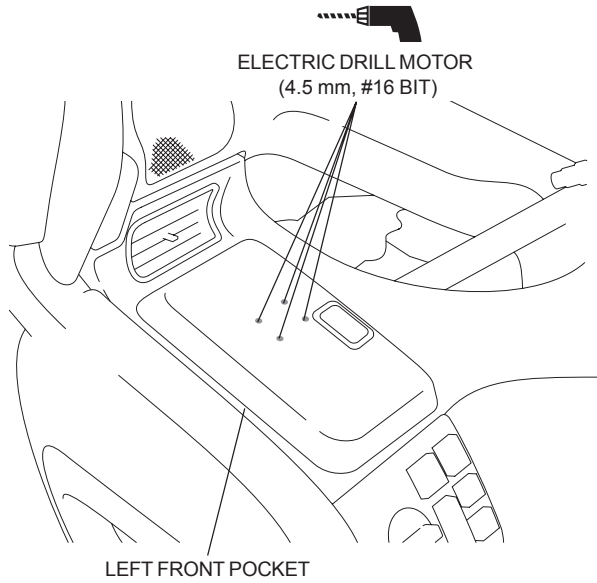

3. Install the fairing pouch base as shown.

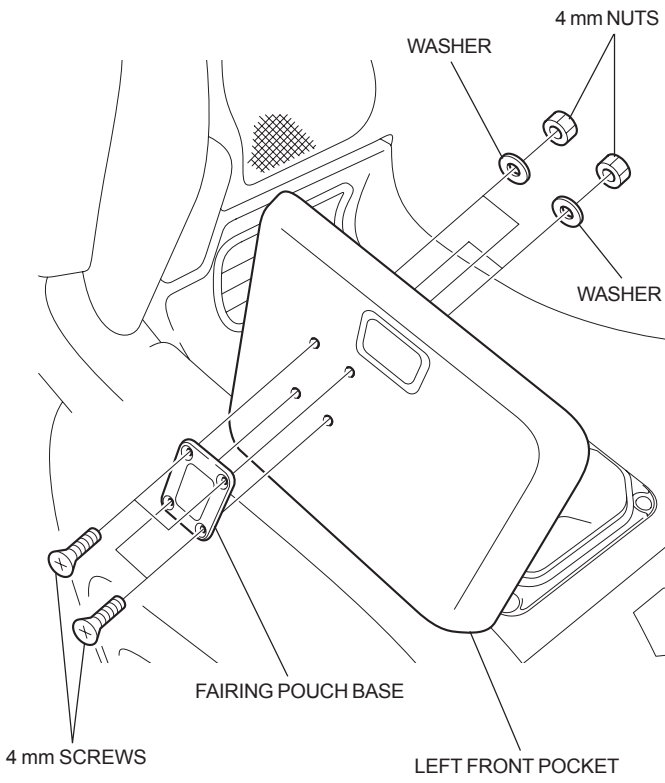

4. Install the fairing pouch as shown.

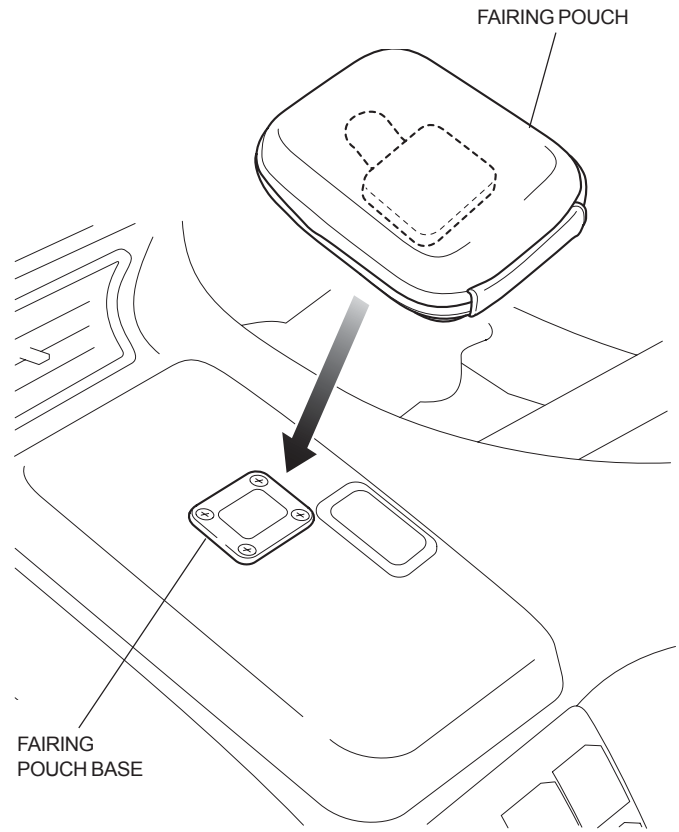

#### How to Remove The Fairing Pouch

